

M3i INDOOR CYCLE INSTALLATION AND OPERATION MANUAL



CONTENTS

03 – IMPORTANT SAFETY INSTRUCTIONS

04 – INTRODUCTION

04 – WEIGHT AND FOOTPRINT

04 – ASSEMBLY

04_TOOLS REQUIRED FOR ASSEMBLY

05_PARTS LIST

06_PRODUCT OVERVIEW

07_MOUNTING THE CYCLE TO THE BASE

07_INSTALLING THE FLYWHEEL AND HUBCAP

08_INSTALLING THE FLYWHEEL GUARD

09_INSTALLING THE PEDALS

10_INSTALLING THE COMPUTER

10_ASSEMBLING THE HANDLEBAR

12_ASSEMBLING THE DEVICE HOLDER

12_APPLY THE HOLE COVER DECALS

12_FINAL INSTALLATION AND CHECKING FOR PROPER
OPERATION

13_SETTING TRIP UNITS TO MILES OR KILOMETERS (KM) AND
BIKE ID NUMBER

14 – M3i SERIES COMPUTER

16 – SET UP AND OPERATION

16_EMERGENCY STOP

16_ADJUSTMENT KNOB INSTRUCTIONS FOR SEAT AND
HANDLEBAR HEIGHT

17_LEVELLER FOOT ADJUSTMENT

17_POSTURE AND BODY POSITION

18_SELECTING SEAT HEIGHT

18_PEDAL PLACEMENT

19_HANDLEBAR HEIGHT ADJUSTMENT

19_SETTING THE FORWARD AND BACKWARD SEAT POSITION

20_OPERATION OF THE CYCLE

21 – MAINTENANCE

21_PREVENTATIVE MAINTENANCE SCHEDULE

22 – COMPUTER BATTERY REPLACEMENT

22 – REGULATORY AND COMPLIANCE NOTICES

23 – WARRANTY

IMPORTANT SAFETY INSTRUCTIONS

1. Read these instructions.
2. Keep these instructions .
3. Heed all warnings.
4. Follow all instructions.
5. Only use replacement parts recommended by Keiser Corporation.
6. Replace defective components immediately and/or keep the equipment out of use until repaired.
7. Routinely check and pay special attention to components most susceptible to wear.
8. Maximum weight of the rider shall not exceed 300 lbs (136 kg).
9. The cycle is NOT designed with a freewheel, but a fixed gear system. When the flywheel is in motion, the pedals will also be in motion.
10. Never remove your feet from the pedals while the flywheel is in motion as serious user injury may occur.
11. Always secure the pedal clip strap by placing your foot on the pedal and in the toe cage. Locate the strap and pull up on it to tighten. It should be snug but not too tight to cause discomfort.
12. The emergency brake allows you to safely slow or stop the motion of the flywheel. Move the emergency brake away from you to increase the gear and slow the motion of the flywheel. Move the emergency brake all of the way forward to engage the emergency stop.
13. This cycle is intended for use in training areas of organizations such as sport associations, educational establishments, hotels, clubs and studios, where access and control is specifically regulated by the owner (person who has the legal responsibility).
14. Keep children and pets clear from the unit at all times, especially while in use. Children shall not play with the cycle. Cleaning and user maintenance shall not be made by children without supervision.
15. This cycle can be used by children aged from 14 years and above and persons with reduced physical, sensory, or mental capabilities or lack of experience and knowledge if they have been given supervision or instruction concerning use of the cycle in a safe way and understand the hazards involved.
16. The cycle should be positioned on a stable, level, horizontal surface.
17. There should be a clearance of no less than 24 inches (0.6 m) of free area on all sides of the cycle. When cycles are positioned adjacent to each other the free area may be shared.
18. Movements such as pedaling at high speeds or pedaling while standing are considered advanced techniques, and should only be performed when the rider has reached an advanced level.
19. Ensure that all adjustment handles that could interfere with the user's movement are not left projecting as to come in contact with the rider during operation.
20. Before dismounting, push the emergency brake to the most forward position to engage the emergency stop.

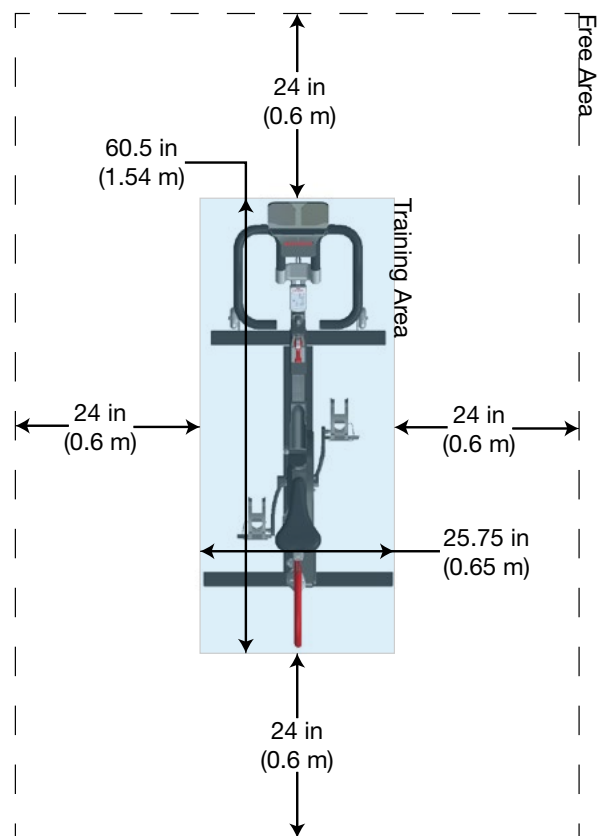

WARNING: This symbol appearing throughout this manual means **PAY ATTENTION! BE ALERT!** When you see this warning symbol, your safety is involved. It is being used to call attention to **POTENTIAL** hazards that could result in personal injury or loss of life.

INTRODUCTION

Thank you for purchasing Keiser's premier M3i indoor cycle. Your new resistance system is a revolutionary way to exercise providing a smoother, quieter, and more predictable workout.

WEIGHT AND FOOTPRINT

Total Weight	91 lbs (41.27 kg)
M3i Footprint	Length 60.5 inches (1537 mm) x Width 25.75 in (654 mm)

ASSEMBLY

- Carefully remove the cycle from the box.
- Carefully unwrap the cycle.



WARNING: Use caution when using a box cutter or other tool with a sharp blade to unwrap the cycle. A sharp tool can cause damage to the seat, handlebar, or scratch the frame of the cycle.

- Layout all the cycle components and compare them to the "Parts List" on page 5.
- Check that all parts are present and undamaged.

NOTE: If parts are missing or damaged contact your local dealer, distributor or Keiser Corporation Service Department.

TOOLS REQUIRED FOR ASSEMBLY

The following tools are required to assemble the cycle but not supplied:

Qty	Description	Qty	Description
1	Torque wrench (Minimum 45 Nm/35 ft-lb)	1	16 mm, or 5/8 inch crowfoot
1	4 inch extension	1	5 mm Allen wrench
1	15 mm open-end wrench	1	6 mm Allen wrench
1	16 mm, or 5/8 inch open-end wrench	1	Paste or spray wax (used to clean after assembly)
1	#2 Phillips screwdriver	1	Clean cloth
1	15 mm crow foot	1	LPS #3 heavy-duty rust inhibitor with straw
2	10 mm wrenches		

PARTS LIST

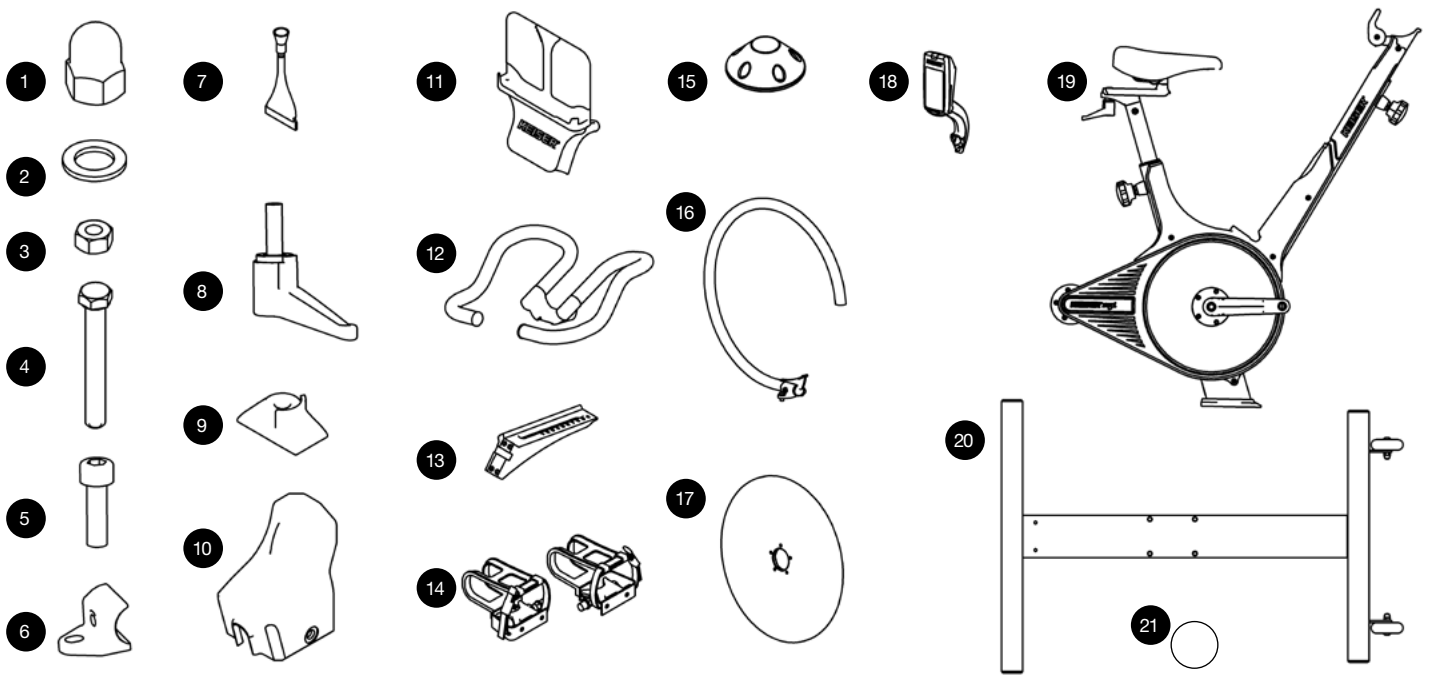

	Description	Qty	Part Number
1	7/16-20 Acorn Nuts	4	555022
2	7/16 Washers	4	9384
3	M6 x 1, Hex Nut	1	9508
4	M6 x 1 x 45, Hex Head Screw	1	9525
5	M6 x 1 x 20, Socket Head Cap Screw	5	9502
6	Flywheel Guard Bracket	2	555025
7	Loctite 242 - Thread Locking Compound	1	105550
8	L-Handle Assembly	1	550828
9	Handlebar Spacer	1	555031
10	Sweat Guard Cover	1	555080
11	Device Holder	1	555085
12	Handlebar	1	550844
13	Handlebar Slide	1	555026
14	Left and Right Pedals	1	540831
15	Hubcap	1	555005
16	Flywheel Guard	1	550845
17	Flywheel	1	555003
18	Computer	1	550853X
19	Cycle - Main Frame	1	550867
20	Base	1	550814
21	Hole Cover Decal	5	555379

PRODUCT OVERVIEW

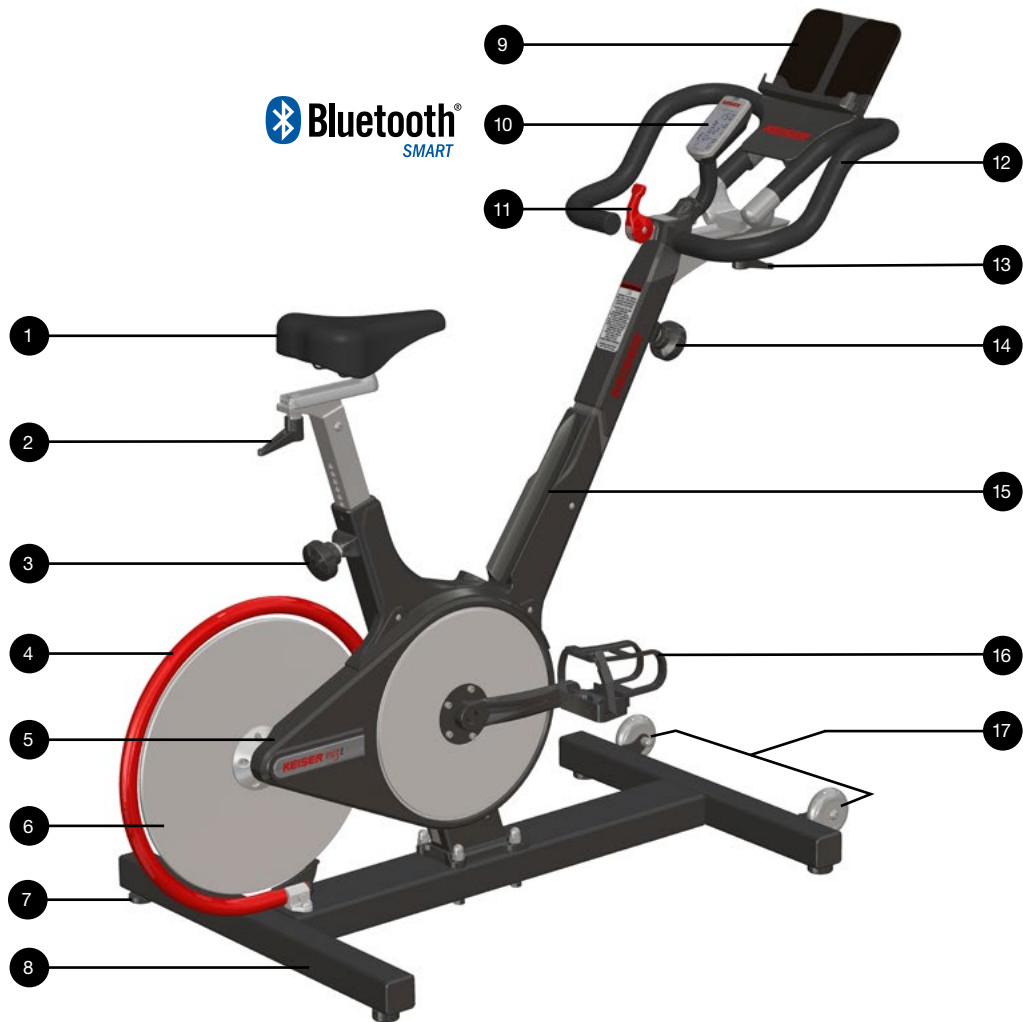

- | | | | |
|---|---|----|--|
| 1 | Seat | 10 | Computer System with Bluetooth® smart |
| 2 | Forward/Backward Seat Adjustment Handle | 11 | Resistance Lever/Emergency Brake |
| 3 | Up/Down Seat Adjustment Knob | 12 | Neutral Position Handlebar |
| 4 | Flywheel Guard | 13 | Forward/Backward Handlebar Adjustment Handle |
| 5 | Belt Cover | 14 | Up/Down Handlebar Adjustment Knob |
| 6 | Flywheel | 15 | Water Bottle Holder |
| 7 | Levelling Foot | 16 | Shimano™ Combo Pedals |
| 8 | Base | 17 | Transport Wheels |
| 9 | Device Holder | | |

MOUNTING THE CYCLE TO THE BASE

NOTE: Due to the weight of the cycle, it is recommended that two people perform this part of the assembly.

1. Align the holes of the cycle with the studs of the base, refer to Figure 1. The front of the cycle should face the wheels of the base.
2. Place the cycle onto the base.
3. Insert a washer (supplied) on each of the four studs.
4. Install an acorn nut (supplied) on each stud and then hand tighten the acorn nuts.
5. Torque the acorn nuts to 45 Nm (35 ft-lbs) using a 16 mm or 5/8" crowfoot attached to a torque wrench.

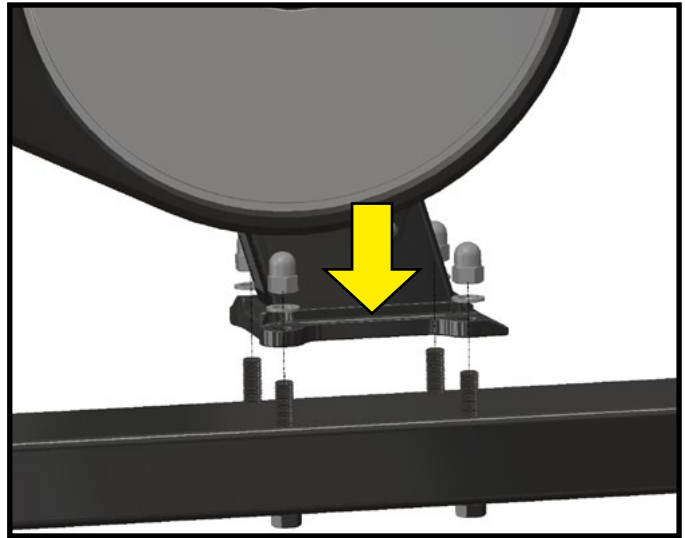

Figure 1. Cycle and Base Alignment

INSTALLING THE FLYWHEEL AND HUBCAP



WARNING: Failure to follow these instructions may cause damage to the flywheel.

1. Place the shifter lever in the downward position, refer to Figure 2.
2. Slide the flywheel between the two magnets and over the hub, refer to Figure 3.

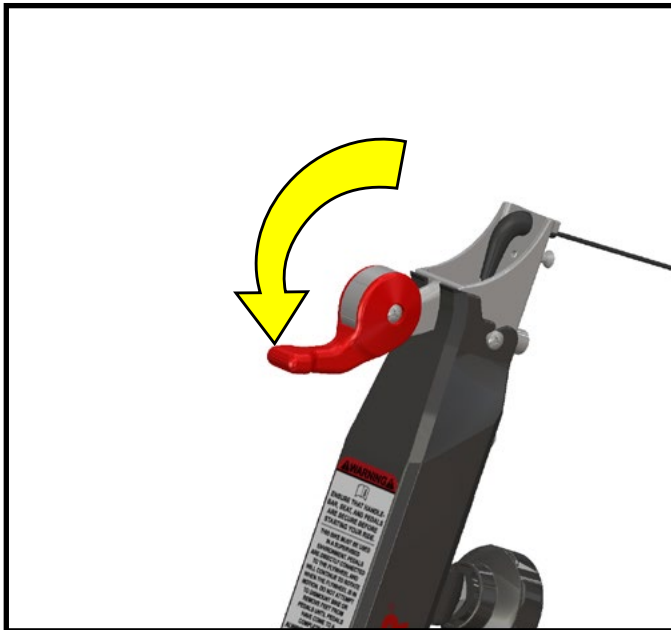

Figure 2. Shifter Lever Position

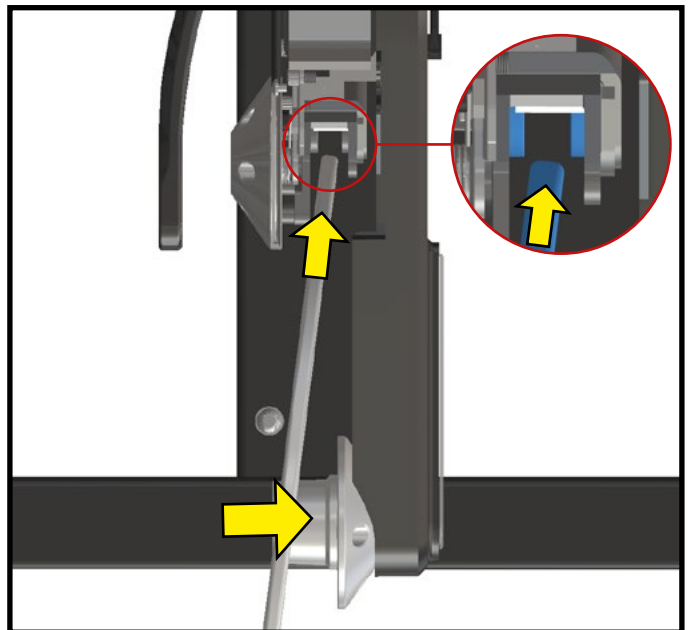

Figure 3. Location of Magnets

3. Align the holes of the flywheel with the holes of the hub.
NOTE: The flywheel should be flush against the hub.
4. Install the hubcap:
 - a) Align the holes of the hubcap with the holes of the flywheel, refer to Figure 4.
 - b) Hold the flywheel in position.
 - c) Use the five, M6x1x20 SS socket head cap screws (supplied) and a 5 mm Allen wrench and tighten the screws.
 - d) Be sure the flywheel is flush against the face of the hub. Spin the flywheel to make sure the it runs true and straight (no wobbling).



Figure 4. Flywheel and Hubcap Installation

INSTALLING THE FLYWHEEL GUARD

NOTE: When installing and centering the guard, try to avoid touching the flywheel with the guard.

1. Remove the two Allen screws and washers from the base frame, refer to Figure 5. Do not discard the screws. They will be used to mount the flywheel guard.
2. Place the open end of the flywheel guard over the mounting stud located on the frame of the cycle, refer to Figure 6.
3. Swing the guard over the flywheel, refer to Figure 7.

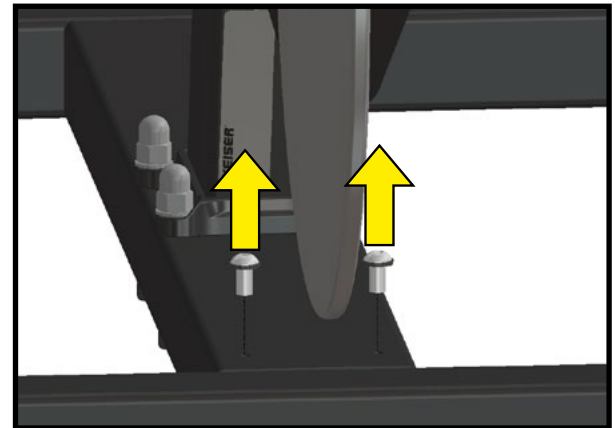

Figure 5. Remove the Allen Screws

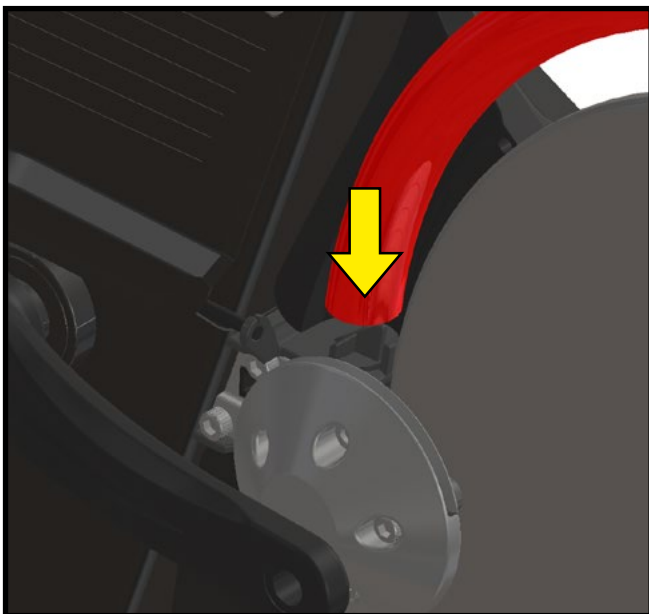

Figure 6. Flywheel Guard Placement

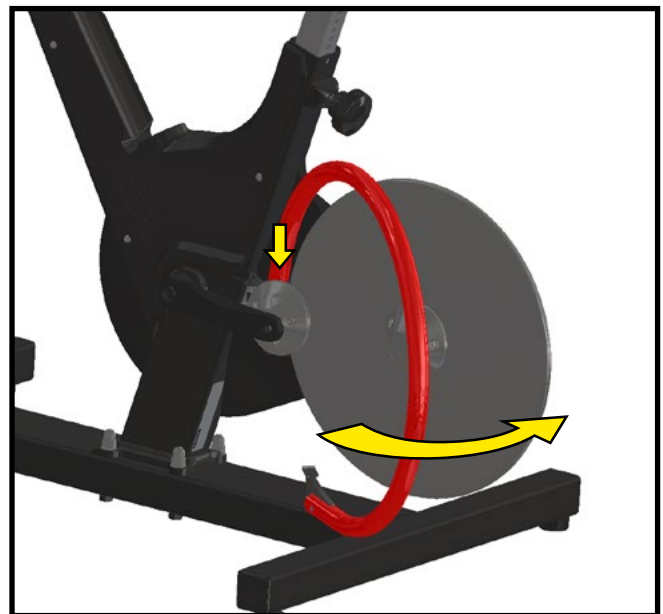

Figure 7. Center Flywheel Guard Over Flywheel

4. Attach the brackets on the end of the flywheel guard, refer to Figure 8. Use the M6 x 1 x 45 hex head screw and nut (supplied). Hand tighten the screw and nut.
5. Tighten the brackets to the base frame with the two Allen screws and washers removed in step 1. Do not fully tighten the bolts.
6. Check to ensure that there is enough clearance between the flywheel and the flywheel guard.
7. Using 2, 10 mm wrenches and a 5 mm Allen wrench, tighten the bolt and screws to secure the flywheel guard centered with the flywheel.

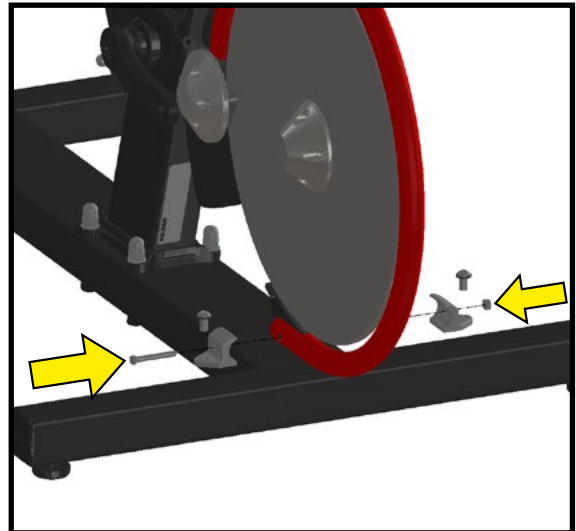

Figure 8. Align, Attach, and Tighten Flywheel Guard Brackets

INSTALLING THE PEDALS



WARNING: Failing to install the pedals with a thread locking compound, or crossing the threads will damage them, and could result in serious injury to the user.

NOTE: A torque wrench with 4 inch extension and 15 mm crowfoot are required to correctly torque the pedals.

1. Unwrap the pedals and the Loctite 242 - thread locking compound.
2. Clean the threads of the pedals with a clean cloth.
3. Apply thread locking compound to the pedal threads.
4. Use a 15 mm open-end wrench and install the pedals:
 - Left Pedal** - Thread the left pedal (marked L) into the left side of the left crank arm by turning it counter-clockwise, refer to Figure 9.
 - Right Pedal** - Thread the right pedal (marked R) into the right side of the right crank arm by turning it clockwise, refer to Figure 10.
5. Tighten the pedals with a torque wrench, 4 inch extension, and 15 mm crowfoot. Torque the pedals to 45 Nm (35 ft-lbs).
6. Apply LPS#3 to the left bottom bracket bearing.
7. Apply LPS #3 to the clip-in portion of the pedals.

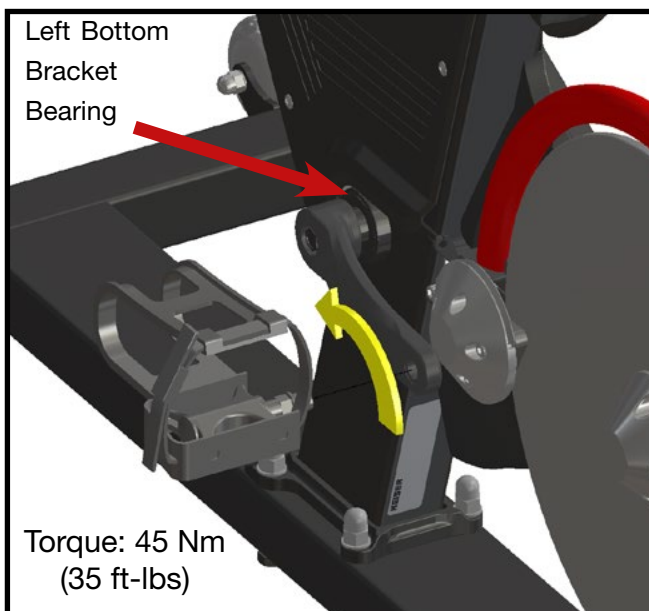

Figure 9. Installing the Left Pedal, Turn Counter-Clockwise

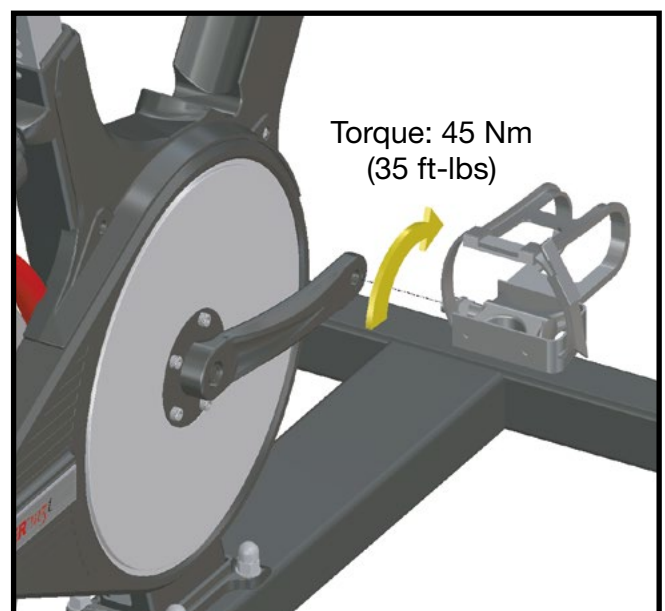

Figure 10. Installing the Right Pedal, Turn Clockwise

INSTALLING THE COMPUTER

1. Use a #2 Phillips screwdriver and remove the computer mounting screw from the handlebar tube, refer to Figure 11.
2. Coil the computer cable into the computer mount

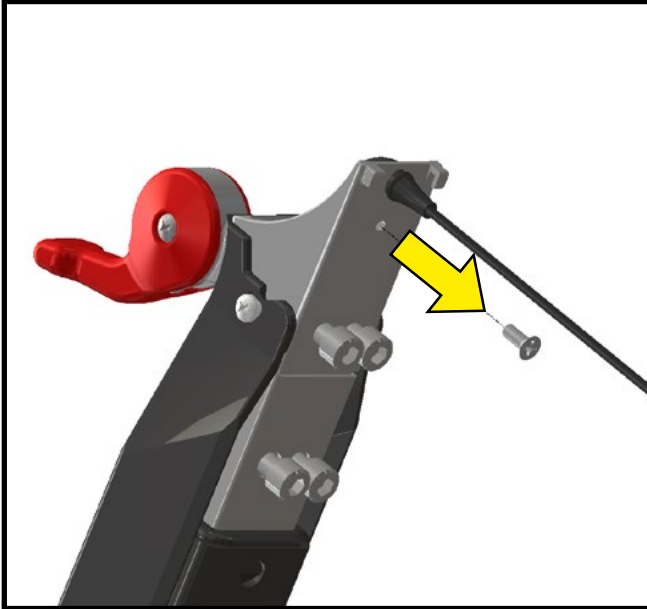

Figure 11. Remove Mounting Screw From Handlebar Tube

3. Slide the computer up into the two locking ears.
4. Insert and secure the computer with the screw previously removed using a #2 Phillips screwdriver.

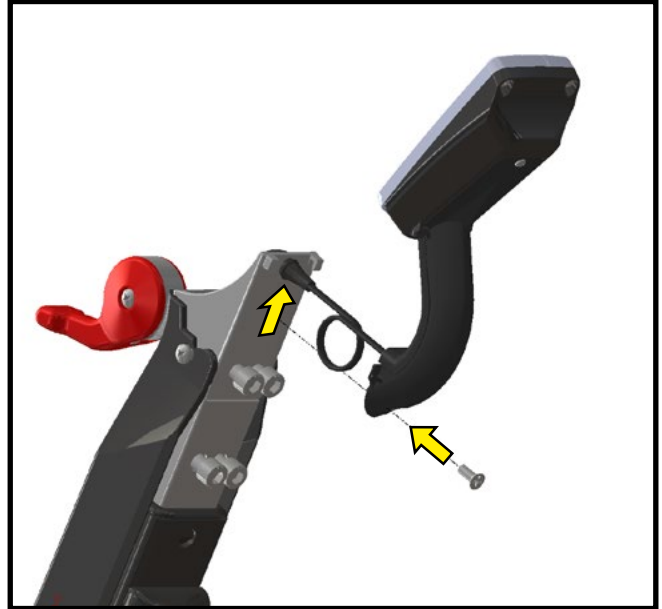

Figure 12. Attach the Computer to the Handlebar Tube

ASSEMBLING THE HANDLEBAR

1. Remove screws from both sides of the sweat guard, refer to Figure 13.
2. Slide on the guard cover over the sweat guard and snap it in place, refer to Figure 14.
3. Secure the cover with the screws previously removed. Do not over tighten screws.
4. Remove the four 8 mm Allen screws from the handlebar tube, located below the computer mount, refer to Figure 15.

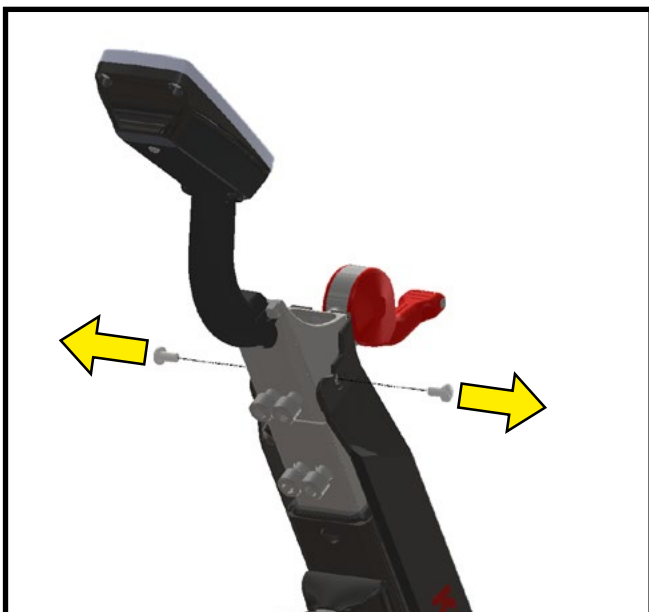

Figure 13. Remove Screws From Sweat Guard

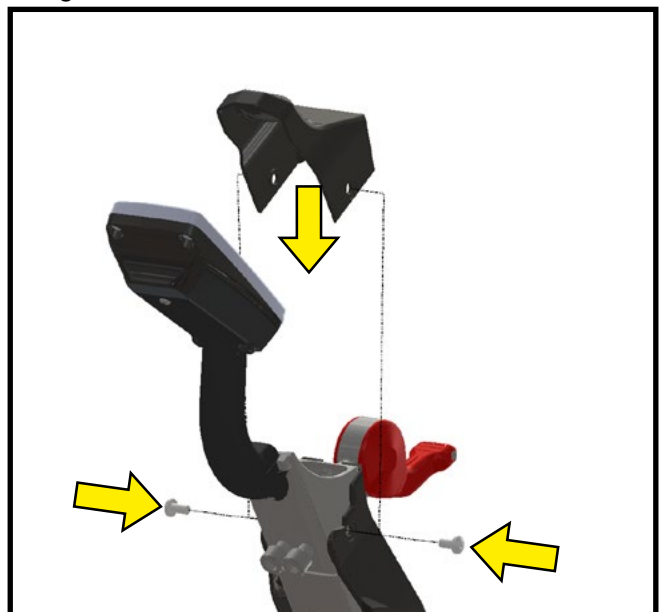

Figure 14. Align the Guard Cover Over the Mounting Holes

5. Attach the handlebar slide to the handlebar tube with the four 8 mm screws previously removed. Use a 6 mm Allen wrench to tighten screws. There should be

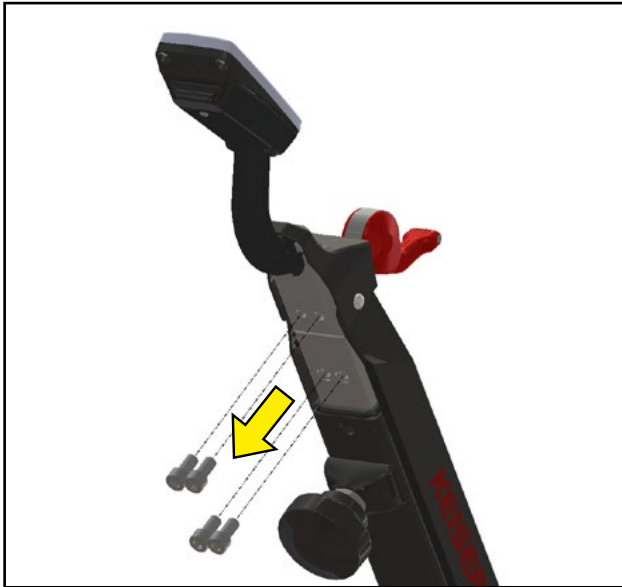

Figure 15. Remove the 8 mm Screws From the Handlebar

no gap between the handlebar slide and the handlebar tube, refer to Figure 16.



Figure 16. Attach the Bottom Slide to the Handlebar Tube

6. Install the handlebar on the handlebar slide:
 - a) Disassemble the L-handle assembly. Use a 5 mm Allen wrench and remove the screw and washer to remove the handle stud.
 - b) Fit the L-handle stud in the handlebar spacer, and then attach the handlebar to the handlebar slide, refer to Figure 17. Hand tighten the assembly.

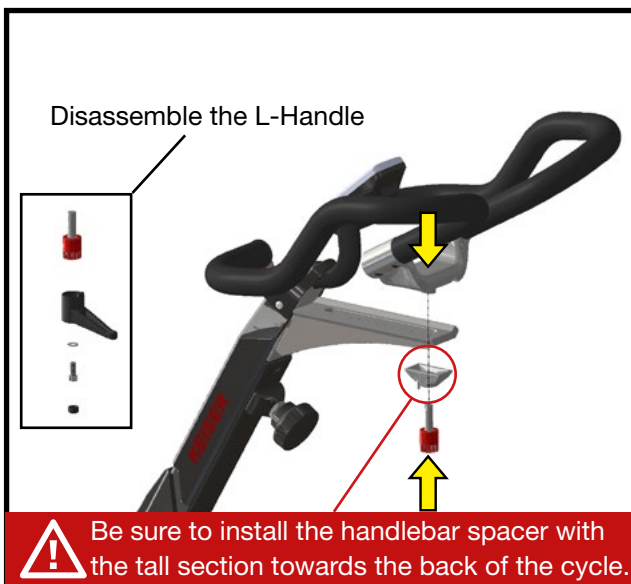

⚠ Be sure to install the handlebar spacer with the tall section towards the back of the cycle.

Figure 17. Assemble Handlebar, Handle Stud, and the Handlebar Spacer

c) Place the L-handle onto the handle stud. The L-handle should point away from the cycle when the handlebar is tight. Install the screw and washer to secure the assembly, refer to Figure 18.

7. Loosen the L-handle. Slide the handlebar back and forth, making sure it can move freely on the handlebar slide.

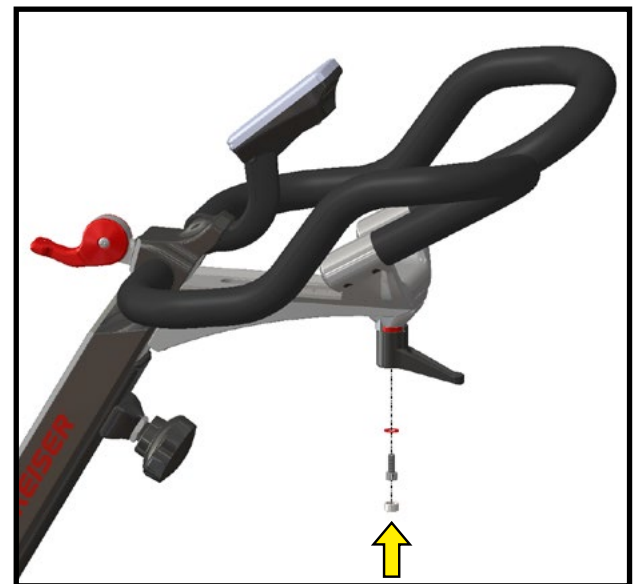

Figure 18. Install L-Handle and Secure with Screw and Washer

ASSEMBLING THE DEVICE HOLDER

To install the device holder, apply force in the direction shown in Figure 19. The device holder will fit to the handlebars as shown in Figure 20.



Figure 19. Assemble the device holder to the handlebar



Figure 20. The assembled handlebar and device holder

APPLY THE HOLE COVER DECALS

Install the hub cover decals as shown in figure 21. The decals should completely cover each of the 5 holes on the flywheel hubcap.

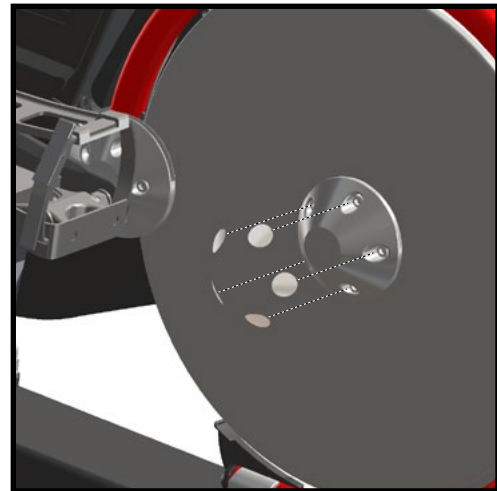

Figure 21. Hole Cover Decal Placement

FINAL INSTALLATION AND CHECKING FOR PROPER OPERATION

NOTE: Perform the operations below before riding the cycle. Failing to test a cycle prior to normal use will void your warranty and could result in serious injury.

- Are all parts correctly installed?
- Are the four Acorn nuts that secure the main cycle frame to the base frame torqued at 45 Nm (35 ft-lbs)?
- Are pedals installed with thread locking compound and torqued to 45 Nm (35 ft-lbs)?
- Are all screws and nuts properly torqued and tightened?
- Do the handlebar and seat adjustments operate properly?
- Was LPS #3 applied to the left bottom bracket bearing?
- Was LPS #3 applied to the clip-in portion of the pedals?
- Is the computer installed and operational?
- Polish the cycle with paste or spray wax and a clean cloth?
- If all assembly requirements have been met, test ride the cycle.

SETTING TRIP UNITS TO MILES OR KILOMETERS (KM) AND BIKE ID NUMBER

(Unless otherwise specified or requested at the time of purchase, the M3i trip distance is set to miles.)

NOTE: STEPS 1 THROUGH 7 MUST BE COMPLETED WITHIN 1 MINUTE



1 Begin with the bike off, push shift lever all the way down

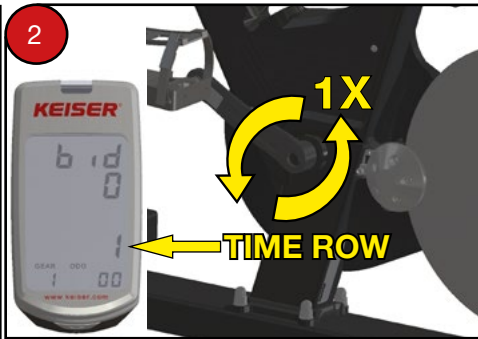

2 Pedal 1 full revolution. The bike id (bid) in the screen above is 0, yours may be different. Also, notice the 1 in the "TIME ROW".



3 Set shift lever to gear 21 for Miles, or set shift lever to gear 19 for Kilometers.

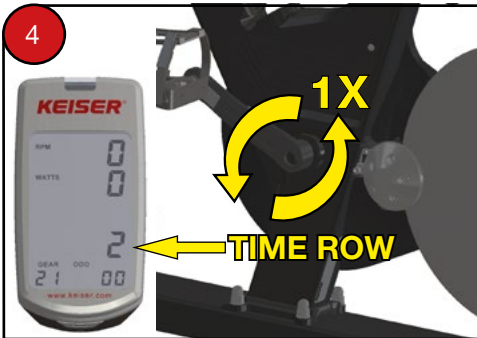

4 Pedal 1 full revolution. Notice the 2 in the "TIME ROW".



5 Set shift lever to gear 19 for Miles, or set shift lever to gear 21 for Kilometers.

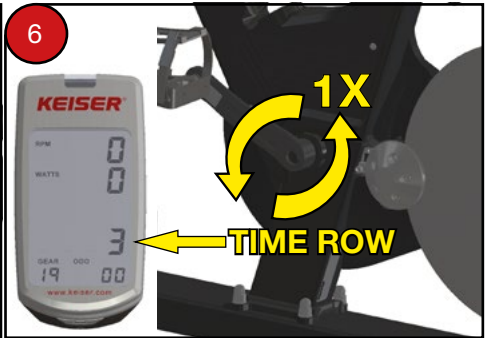

6 Pedal 1 full revolution. Notice the 3 in the "TIME ROW".



7 Move the shift lever from stop to stop 6 times.

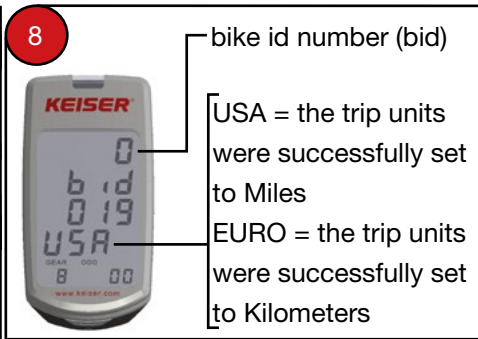

8 Confirm the correct units have been set.

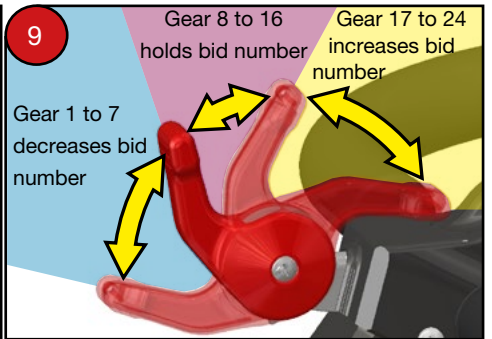

9 Once the trip units have been set, you have the opportunity to adjust the bike id number. Adjust the shift lever to attain the desired bike id number, then set the shift lever to any number between gear 8 and 16.

NOTE: The computer will only shut down while the shift lever is between gears 8 and 16.

M3i SERIES COMPUTER

LINE 1 - BACKLIGHT SENSOR

While the M3i series computer is awake, the backlight sensor automatically detects ambient light levels in the room and turns on the backlight display when needed.

LINE 2 - RPM (CADENCE)

The RPM displays the cyclist's revolutions per minute of the crank arm. RPM is also known in the cycling world as cadence and is roughly the speed at which the cyclist is pedaling.

LINE 3 - POWER AND ENERGY

The power output is displayed in Watts (currently generating) and Kilocalories (total value for the workout). The computer toggles back and forth between Watts for 8 seconds and Kilocalories for 2 seconds. The rated accuracy for power between 30 and 160 rpm is ± 5 Watts for Power below 50 Watts, and $\pm 10\%$ for power above 50 Watts.

LINE 4 - HEART RATE

If there is no Heart Rate signal, a steady heart symbol and a zero will be displayed. If a participant is wearing a Heart Rate strap, once the computer locks onto the signal, the heart symbol will blink and display the heart rate. Please note that the Heart Rate strap must be Polar compatible and coded.

LINE 5 - ELAPSED TIME

The number shown reports the total time spent cycling and will reset to zero after 60 seconds of inactivity or if the computer is reset using the gear shifter.

LINE 6 - GEAR

Gears from 1 to 24 are displayed on the bottom left hand of the screen.

LINE 7 - ODOMETER/TRIP DISTANCE

For the first 8 seconds when the computer is activated, the odometer will display the total distance the cycle has been ridden. This feature is for service and maintenance purposes only. After 8 seconds, the odometer will disappear, the trip units will display "USA" for trip distance set to Miles, or "EURO" for trip distance set to Kilometers. As soon as the units disappear, trip will display for the remainder of the workout. Note, to change the trip units, see instructions for setting bike id and trip units to miles/kilometers.

AVERAGE CALCULATIONS

To view averages: RPM (Cadence), Power, and Heart Rate at any point in the workout, stop pedaling for three seconds. This will flash your averages until you start pedaling again or until the computer goes to sleep after 60 seconds.

INTERVAL TRAINING

To initiate an interval, starting from a high gear drop the shifter handle to gear 1 for 1/4 of a second and lift it up to a higher gear immediately. "inL #" will display confirming the interval has started.

Repeat the above steps to end the interval. When the interval ends the computer will display "inL End" and the averages for that interval will blink. Note, the averages that show at the end of your ride when pedaling has stopped are inclusive of all pedaling time and intervals that have taken place during the ride.

Bluetooth® smart ENABLED

The Bluetooth Smart enabled computer allows Bluetooth Smart Ready devices such as cellphones, tablets, and computers to gather information about the ride. M3i compatible apps allow data to be stored to track progress over time and make the data available to other fitness applications. Classrooms are able to utilize real time performance tracking programs which give the entire class an opportunity to see their performance compared with others in the class.

Note: For the first revolution of the pedal during startup, lines 2 and 3 will display "bid" and any number 0 to 150. If set up correctly in a group cycle environment, bid (bike identification) represents an identifiable numerical value specific to each individual cycle.

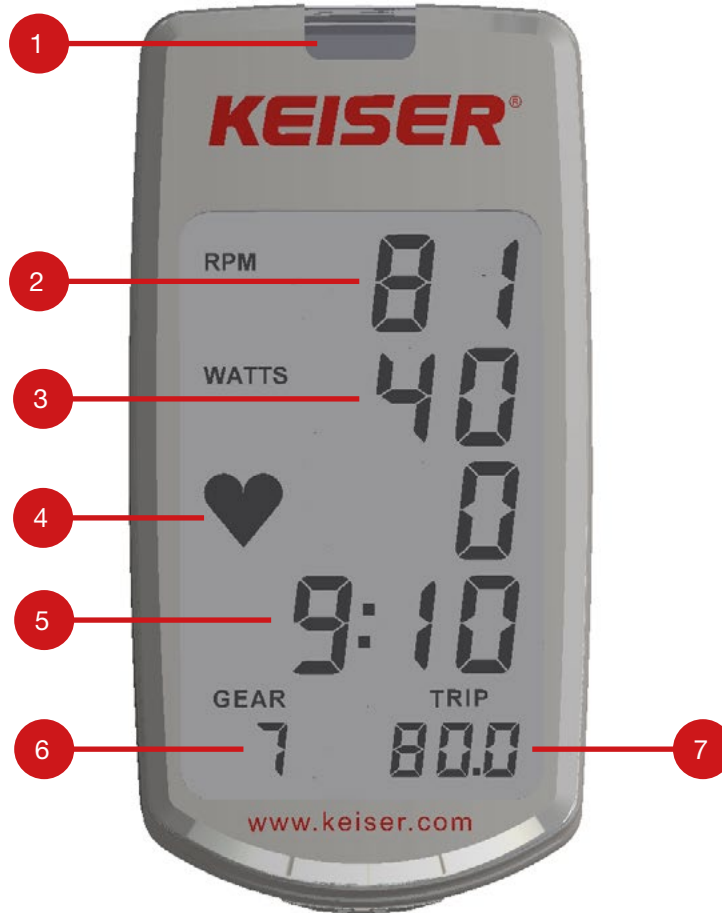

Figure 22. M3i Computer Overview



WARNING: Heart rate monitoring systems may be inaccurate. Over exercising may result in serious injury or death. If you feel faint stop exercising immediately.

SET UP AND OPERATION

The M3i cycle is intended for cardiovascular workout. Special programs have been designed for group exercise environments. The cycle must always be used in a supervised area under control of a trained and authorized instructor. The following pages are a brief overview of the features necessary for safe operation of the cycle.

EMERGENCY STOP

The shift lever can be used as an emergency brake to stop the motion of the flywheel. To use the resistance shifter as an emergency brake, move the lever all the way forward to stop all motion within one revolution, refer to Figure 23. With any braking procedure, wait until the pedals and flywheel come to a complete stop before dismounting.

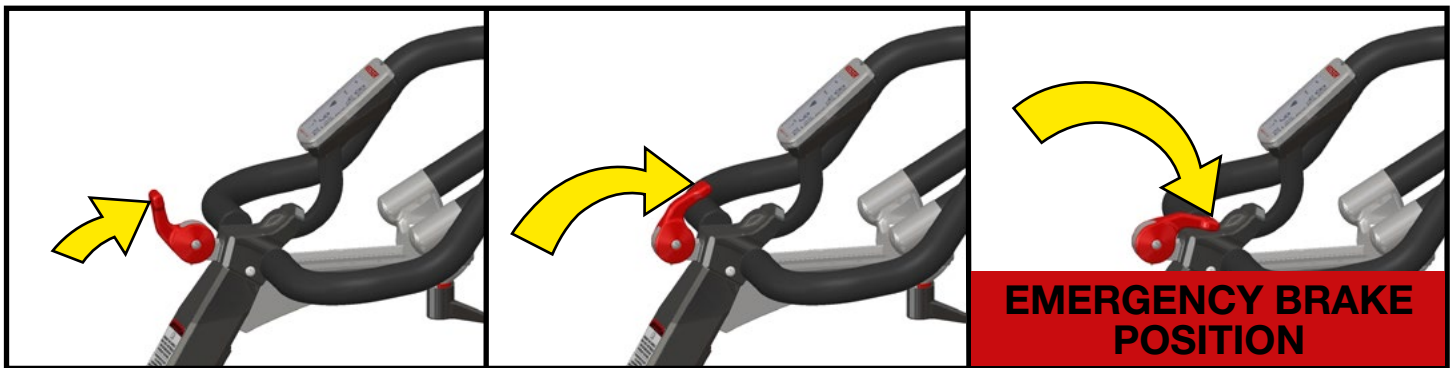

Figure 23. Emergency Brake Position

ADJUSTMENT KNOB INSTRUCTIONS FOR SEAT AND HANDLEBAR HEIGHT

(The seat adjustment knob is shown, the handlebar vertical adjustment knob operates in the same manner)

Refer to Figure 24, turn the adjustment knob counter clockwise until it loosens. Pull the knob out towards you. While holding the knob raise or lower the seat/handlebar post to reach the desired position. Re-engage the knob ensuring it locks into the desired hole in the seat/handlebar post. Turn the knob clockwise until it is hand tight. Check the seat/handlebar post to ensure it is secure; there should be no movement in any direction.

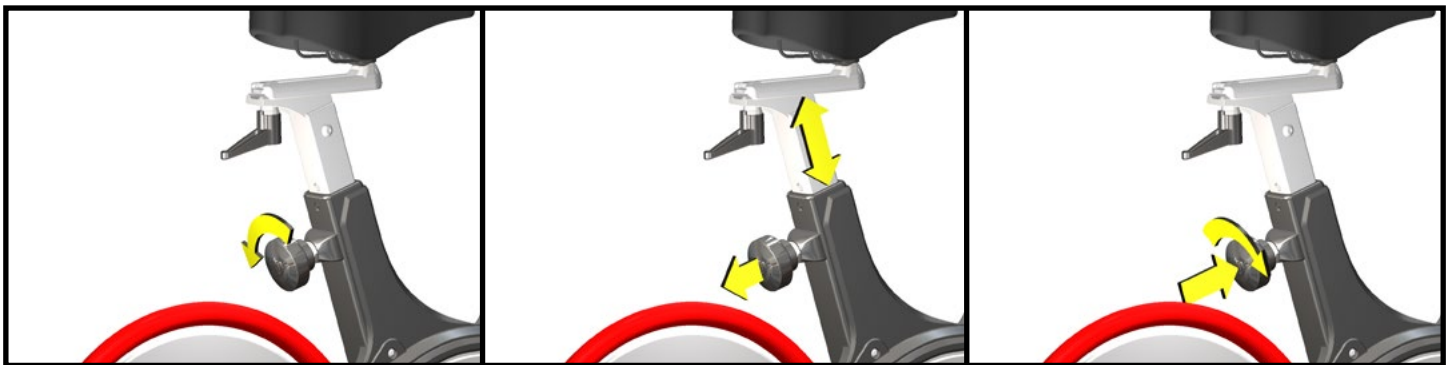

Figure 24. Pull Pin Instructions

LEVELLER FOOT ADJUSTMENT

The leveller foot is located on the left rear corner of the base frame. The leveller foot is adjusted by slightly lifting the appropriate corner of the cycle and screwing the foot clockwise or counterclockwise.

If the cycle requires levelling, rotate the foot inwards (or counterclockwise from a topside view) until the cycle is resting on the 3 fixed feet. Next, with the cycle resting on the 3 fixed feet, rotate the leveller foot out (or clockwise from a top view) until it just comes in contact with the floor. Test the cycle for stability, fine tune adjust the leveller foot as needed.



Figure 25. Leveler Foot Adjustment

POSTURE AND BODY POSITION

Keiser recommends that the back is always in a neutral position. To avoid injury, maintain good posture and control of both the upper and lower body, refer to Figure 26.



Figure 26. Basic Posture

SELECTING SEAT HEIGHT

WARNING:



- Maximum weight of the rider shall not exceed 300 lbs (136 kg).
- If the hips rock back and forth with each pedal stroke, the seat position may be too high. Uneven rocking from side to side may result in hip or back injuries.
- If a participant's knees are bowed outward (beyond their normal ergonomic position), the seat may be too low. If the knees are too flexed, unwanted stress is placed on the knee caps. The knee should never be in an overextended position.

1. Stand beside the cycle, close to and beside the seat of the cycle.
2. Position the seat so that the top of the seat is level with the crest of the hip.
3. Sit on the seat with the balls of the feet over the center of the pedals.
4. Begin to pedal very slowly.

NOTE: When the foot is in the six o'clock position there should be a slight bend in the knee. See Figure 27.



Figure 27. Slight Bend in Knee at Six O'Clock Position.



WARNING: Seat height adjustment shall not exceed the mark "STOP" indicating minimum insertion depth for safe operation.



PEDAL PLACEMENT



WARNING: The indoor cycle is NOT designed with a freewheel, but a fixed gear system. When the flywheel is in motion, the pedals will also be in motion. Never remove your feet from the pedals while in motion as serious user injury may occur.

Always secure the pedal clip strap:

1. Place the widest part of foot over the pedal.
2. Locate the strap and pull up on it to tighten. It should be snug but not too tight to cause discomfort.

NOTE: Pedaling at high speeds or pedaling while standing are considered advanced techniques, and should only be performed by advanced users.



Figure 28. Foot Placement in Pedal

HANDLEBAR HEIGHT ADJUSTMENT



WARNING: Placing the handlebars too low may over-stress the arms, mid back and neck. Maintain a high, comfortable position until a higher skill level is reached.

1. The handlebar should be adjusted after performing the seat height adjustment.
2. The handlebar should be level or higher than the top of the seat.
3. Bend elbows slightly and place shoulders at a 90° position.



Figure 29. Overhand Front Handlebar Grip



Figure 30. Hook or Middle Handlebar Grip

NOTE: New cyclists are encouraged to keep their handlebar in a high, comfortable position to take any strain off of their back.



Figure 31. Extended Handlebar Grip



Figure 32. Time Trial Handlebar Grip

SETTING THE FORWARD AND BACKWARD SEAT POSITION

1. Adjust the seat to the correct height position.
2. Sit on the seat of the cycle.
3. Place hands on the handlebars and adjust the handlebars forward or backward.
 - NOTE: Arms should be a comfortable distance from the handlebars with the elbows slightly bent.
4. Place feet on the pedals in the three-o'clock and nine-o'clock position.
 - NOTE: The front of the knee cap should be aligned with the middle of the pedal at the point where the crank arm meets the pedal.
5. Bend elbows slightly and place shoulders at a 90° position.
6. Look down:
 - If toes are visible move/shift the seat back.
 - If the entire foot is visible move/shift the seat forward.

NOTE: Adjust and re-check the knee cap alignment. The knees should not extend beyond the elbows when pedaling.

OPERATION OF THE CYCLE

Once the cycle has been properly assembled, levelled, and adjusted test ride your cycle and make any fine tune adjustments as needed. It is recommended that the cycle is pedaled in a forward rotation.

There are 2 primary cycling positions to be aware of:

1. The seated position, Figure 33, is best suited for warm ups, training, and cool down. This is the best position for beginners and all around workouts. All four grip configurations as shown in figures 29 through 32 should be achievable in the seated position.
2. For advanced users, the hill climb or standing position, Figure 34, is best suited for advanced workouts. A firm grip of the handlebars is required with great control to prevent injury. In all situations, be sure to consult with your instructor prior to attempting a maneuver that you may not be comfortable with. A Keiser Foundations trained instructor will be able to assist in all aspects of cycle set up and riding technique.



Figure 33. Seated Riding Position

Please remember to:

- Thoroughly stretch and warm up prior to your ride.
 - Ensure that handlebar, seat, and pedal adjustments are secure before starting your ride.
 - Enjoy your workout.
 - Take the time to pedal during a cool down period.
 - Download the ride averages to any Bluetooth® smart capable phone or tablet with an M3i capable application.
 - Stretch after every workout.
-



Figure 34. Hill Climb or Standing Riding Position

MAINTENANCE

PREVENTATIVE MAINTENANCE SCHEDULE



WARNING: The safety level of the equipment can only be maintained if it is regularly inspected for damage and wear. Immediately replace defective parts and do not use the equipment until all repairs have been completed and thoroughly tested.

Every Class	<ul style="list-style-type: none"> • Thoroughly inspect the cycle to make sure it is in safe proper working order. • Wipe off sweat with a soft towel or cloth.
Weekly - 1st Month	<ul style="list-style-type: none"> • Check the crank arms and re-torque the pedals to 35 ft-lbs (47 Nm). • Check to ensure all screws, bolts and nuts are tight. • Check and re-torque the nuts securing the main frame to the bottom frame to 35 ft-lbs (47 Nm).
Weekly	<ul style="list-style-type: none"> • Thoroughly inspect the cycle to make sure it is in safe proper working order. • Use warm water and a soft cloth to clean the parts of the cycle that are dirty or come in contact with sweat. Do not use household or industrial cleaners, because they can destroy the protective finish of the paint. If you need to use soap, use a mild dish washing soap followed by an automotive treatment such as Meguiar's Quick Detailer Mist and Wipe. • Check the computer for low battery indication. IF YOU HAVE MULTIPLE CYCLES, WE SUGGEST ALL COMPUTER BATTERIES BE CHANGED AT THE SAME TIME (2 AA batteries per bike). See "Computer Battery Replacement" on page 22. • The saddle upholstery and pedal straps are most susceptible to wear. Be sure to check these parts on a weekly basis, at a minimum, and replace at the first sign of wear.
Monthly	<ul style="list-style-type: none"> • Check the crank arms and re-torque the pedals to 35 ft-lbs (47 Nm). • Check to ensure all screws, bolts and nuts are tight. • Check and re-torque the nuts securing the main frame to the bottom frame to 35 ft-lbs (47 Nm). • Check to ensure the four bolts attaching the bottom slide of the handlebar are tight. There should be no looseness or gap between the bottom slide and the slide mount. • Wax areas of the cycle that come in contact with sweat and that are vulnerable to rust. Use an easily applied automotive treatment such as Meguiar's Quick Detailer Mist and Wipe. Please note that failure to apply a coat of wax to high sweat areas at least once a month will decrease paint and frame life due to corrosion and will void the warranty. • Remove, clean, and lubricate the threads on the adjustment handles. Since both the threaded stud and the threaded nut are stainless steel it is very important to keep the threads lubricated with a heavy grease, preferably white or clear in color, such as Hydrotex MT-55 or Dow Corning 111.

COMPUTER BATTERY REPLACEMENT

If the battery is low the Odometer (ODO) setting will display “LO-BA”.

To replace the batteries:

1. Remove the screw from the back of the computer housing.
2. Remove the two old AA batteries. Be sure to dispose of the batteries with a licensed waste collector.
3. Install two new AA batteries with the correct orientation as shown inside the battery housing. Replace the batteries with AA, R6 or LR6 type batteries only. Do not use FR6 or similar type batteries.
4. Replace the back to the computer housing and tighten the screw.



Figure 35. Battery Compartment



WARNING: Do not burn batteries. Do not place batteries in waste bins. Batteries must be disposed of by a Licensed Waste Collector. Battery leakage is extremely caustic and contact with bare skin should be avoided. In the event that battery leakage comes in contact with your skin, flush the area for 15 minutes with copious amounts of water and seek medical attention. Gloves, overalls, safety shoes and eye protectors must be used when handling leaking batteries. Follow manufacturer's recommendations when handling and maintaining batteries.

M SERIES CARDIO CALIBRATION

All M Series equipment is calibrated with a tool at the factory and there is no need to calibrate, unless a component associated with the resistance mechanism or computer require service.

REGULATORY AND COMPLIANCE NOTICES

COMPLIANCE

This device complies with Industry Canada licence-exempt RSS standard(s). Operation is subject to the following two conditions: (1) this device may not cause interference, and (2) this device must accept any interference, including interference that may cause undesired operation of the device.

Le présent appareil est conforme aux CNR d'Industrie Canada applicables aux appareils radio exempts de licence. L'exploitation est autorisée aux deux conditions suivantes : (1) l'appareil ne doit pas produire de brouillage, et (2) l'utilisateur de l'appareil doit accepter tout brouillage radioélectrique subi, même si le brouillage est susceptible d'en compromettre le fonctionnement.

REGULATORY NOTICE

Note: This equipment has been tested and found to comply with the limits for a Class B digital device, pursuant to part 15 of the FCC Rules. These limits are designed to provide reasonable protection against harmful interference in a residential installation. This equipment generates, uses and can radiate radio frequency energy and, if not installed and used in accordance with the instructions, may cause harmful interference to radio communications. However, there is no guarantee that interference will not occur in a particular installation. If this equipment does cause harmful interference to radio or television reception, which can be determined by turning the equipment off and on, the user is encouraged to try to correct the interference by one or more of the following measures:

- Reorient or relocate the receiving antenna.
- Increase the separation between the equipment and receiver.
- Connect the equipment into an outlet on a circuit different from that to which the receiver is connected.
- Consult the dealer or an experienced radio/TV technician for help.

The Bluetooth® word mark and logos are registered trademarks owned by Bluetooth SIG, Inc. and any use of such marks by KEISER is under license. Other trademarks and trade names are those of their respective owners.

- Changes or modifications not expressly approved by Keiser Corporation could void the user's authority to operate the equipment.
- Upon end of life of this cycle, be sure to remove the batteries and scrap the machine according to your local laws and regulations.

WARRANTY

The Keiser M3i Indoor Cycle is warranted to the original purchaser, to be free from defects in materials and workmanship.

NOT COVERED UNDER WARRANTY

- Loss caused by accident, abuse, improper use or neglect.
- Improper maintenance.
- Improper assembly by the purchaser.
- Failure to follow instructions as stated in any of the manuals provided with the Keiser M3i.

The warranty terms begin with the date of original delivery to be evidenced by appropriate shipping documents. Any alteration of the equipment so listed without express written consent of Keiser shall constitute a waiver by the buyer of this warranty. This warranty does not cover other brand name products distributed, but not manufactured by Keiser, which are subject to their respective manufacturers warranties. During the warranty period, warranted defects will be repaired at Keiser, Fresno California, or the defective part will be replaced, at the option of the manufacturer, without charge for either parts or labor to repair the defective part. This warranty does not cover the removal of the defective part and installation of the repaired part. All claims under the warranty must be in writing and authorization obtained from the manufacturer, Keiser, to return the defective parts for exchange. Defective parts must be returned to Keiser. The customer is responsible for all transportation costs on returned items to and from the point of manufacture.

Users, agents, or anyone directing the use of said equipment shall determine the suitability of the product for its intended use, and said parties are specifically put on notice that they shall assume all risk and liability in connection herewith.

The foregoing warranties are in lieu of and exclude all other warranties not expressly set forth herein, whether expressed or implied by operation of law or otherwise,

including but not limited to any implied warranties of merchantability or fitness. Keiser shall in no event be liable for incidental or consequential losses, damages or expenses in connection with exercise products. Keiser's liability hereunder is expressly limited to the replacement of parts not complying with this warranty or, at Keiser's election, to the repayment of an amount equal to the purchase price of the parts in question. Keiser is not responsible for labor charges incurred in the replacement of defective parts. Keiser may, at its discretion, require the return of all defective parts. The customer is responsible for all transportation costs on warranted items to and from the point of manufacture. Replacement products are warranted for the balance of the original warranty period.

All Keiser equipment sold by Keiser distributors, dealers, or salespeople must be registered for warranty purposes. The warranty registration form must be filed within seven days of the sale or installation. Keiser equipment exported out of the US or Canada will be void of warranty unless purchased directly through a Keiser international distributor or dealer in the country of installation, or direct from Keiser's international division.

If you experience any problems please contact our Service Department on:

phone: 559.256.8000 | toll free: 1.800.888.7009 |
email: service@keiser.com



Scan this QR Code with your smart phone or tablet to access the interactive online warranty registration form.
<http://keiser.com/warranty/registration>

KEISER CORPORATION
2470 S. Cherry Ave.
Fresno, CA 93706
WWW.KEISER.COM

Keiser, the Keiser logo, and other trademarks associated with Keiser products referred to in this publication are trademarks of the Keiser Corporation.
All other product names and services are the property of their respective companies.
© Copyright 2015, Keiser Corporation. All rights reserved.